

Rasonic
樂信牌

RSB-BB212S/ RSB-BV212S

迷你雙層蒸煮盒 Mini Double-deck Steam Box



僅適用於家庭使用
For household use only

使用說明書

OPERATION MANUAL

- 在使用本產品前，請仔細閱讀本說明書，閱讀後小心收藏，以備日後查閱。
- Please read the operation manual carefully before using. Keep it in a safe place for future reference.
- 本說明書中的圖示可能有與實物不同的地方，僅供參考。
- Some figures in this manual may not match with the real object, just for reference only.

非常感謝您選購樂信牌迷你雙層蒸煮盒。使用前，請先詳細閱讀本說明書，並保存以備日後參考。

目錄

1. 安全注意事項
2. 清潔及保存注意事項
3. 產品規格
4. 產品結構
5. 使用方法
6. 故障排除
7. 特別聲明
8. 售後服務

1. 安全注意事項

使用本產品前，請先仔細閱讀相關說明。不遵循或忽視這些安全注意事項會導致火災、觸電或個人傷害。

1. 使用前，請將產品的包裝物料全部取出及棄掉，並使用中性的清潔劑配合海綿清洗不銹鋼盒。
2. 接通電源前，請確保開關按鈕未被按下。檢查當地電壓是否與產品額定電壓相符，並將插頭插入合適及有良好接地的插座上。切勿使用電線拖板，以免因電力負荷過度而導致火警或危險。
3. 切勿使用外置計時器或遙控系統來操作本產品。
4. 切勿直接於注水格內(發熱盤上)加熱食物。
5. 切勿在以下環境使用本產品：
 - 不平穩的表面；
 - 潮濕或接近水源的地方；
 - 靠近熱源及火源的地方(如焗爐、電磁爐等)；
 - 易燃物料或不耐熱物品附近(如地毯、塑膠枱布、窗簾及毛巾等)；
6. 如注水太多或超出“最高水位”線位置，有可能造成溢瀉或大量蒸氣噴出等危險。
7. 切勿於運作中途打開頂蓋，否則沸水會濺出引致燙傷。如需打開頂蓋，必須先按開關按鈕關掉產品，方可打開頂蓋。
8. 檢查食物時，建議使用長把手的用具。取出食物時，為免被蒸氣燙傷，請使用隔熱手套。
9. 產品上方不得放置任何物品，切勿遮蓋或阻擋產品的頂蓋及散熱位，防止產品過熱、變形或變色等情況。
10. 請預留足夠空間供產品於加熱時排氣及散熱，建議於產品上方及兩側預留至少10厘米空間。

11. 使用前，請確保電源插頭已徹底連接，否則會因接觸不良導致電源線過熱，影響產品的運作，加速產品損壞或引起火災。
12. 本產品備有過熱保護功能。如需連續使用，建議於首次操作後暫停20分鐘，待產品冷卻後方可再重新使用；乾水停機屬產品保護裝置，切勿依賴此方式關閉產品。
13. 本產品沒有計時功能，用戶須自行因應所需烹調時間注水或切斷電源。以最高注水量(達“最高水位”位置)為例，整體操作時間約30分鐘。**注意！整體加熱時間會因注水而延長。**
14. 按下開關按鈕時，切勿用力過度，以免損壞按鍵。使用後，關掉電源及拔出電源插頭，避免因長時間通電導致內部電子組件損毀，甚至引起火警。
15. 避免烹調過酸或過鹹的食物。
16. 使用一段時間後，機身或配件可能會有染色情況。此乃食材本身的色素、油脂、澱粉質及蛋白質等所致，屬正常現象，無損健康，並不影響使用。
17. 當注水格沒有水時，請勿啟動本產品。如出現乾燒情況，請立即注水或拔掉電源插頭。注水時請小心，切勿用手接觸發熱板，以免造成燙傷。
18. 切勿讓本產品在無人看管或注水格沒有水的情況下運作。
19. 完成烹調後，關閉產品電源及拔掉電源插頭，靜候數分鐘後再打開頂蓋，以免被餘熱灼傷。因機內仍有大量水氣，產品頂蓋會有水珠(倒汗水)凝結，此乃正常現象。小心打開頂蓋，避免水珠從頂蓋掉落開關按鈕或電源接駁位。
20. 若有兒童在旁，須加倍小心使用本產品及看管兒童，以確保他們不會把本產品當作玩具。切勿讓兒童單獨使用、清潔及保養此產品，並將本產品及其電源線置於遠離他們的地方。
21. 使用時，將有大量蒸氣從排氣口冒出！切忌將手、面或身體靠近排氣口，避免灼傷，亦避免將本產品貼靠牆壁或家具使用。

22. 運作過程中，切勿打開頂蓋、移動或搖晃本產品。否則，有可能引致大量蒸氣冒出而造成燙傷或其他危險。使用時或剛使用後，切勿觸摸外殼或發熱部件，以免被高溫及餘熱灼傷。
23. 每次使用後，必須將產品徹底清潔。切勿將本產品機身、電源線、插頭浸入水中，或用水沖洗電源接駁位或讓其接觸到水份，以免影響本產品的安全性能或構成觸電危險。使用前，必須確保插頭已充分擦乾。
24. 小心使用電源線，不可在電源線上放置重物或夾住電源線；不可改裝、用力拉扯或扭曲電源線；在拔出或插入插頭時，應用手握穩插頭，並確保將電源線與產品本身及電源插座接駁良好。否則可能會發生危險或損毀機件。
25. 切勿在電源線纏結的情況下使用本產品，或將電源線懸掛在桌子、櫥櫃的邊緣或讓其接觸發熱的表面，否則會加快電源線的損耗及損壞產品。
26. 使用後或長期不使用時，請拔下電源插頭，以免因長期通電導致內部組件絕緣老化而引致漏電。切勿用濕手接觸、插上或拔除插頭，否則有可能引致觸電。
27. 經常清理插頭上的塵埃，保持產品清潔及不沾油污，以免引起火災。
28. 切勿將本產品用於室外及烹飪以外的其他用途。(否則，有可能發生故障或產生危險。)
29. 本產品可供年齡在8歲或以上的兒童及體質、感覺或智力有障礙人士或缺乏經驗和相關知識的人士使用，但他們必須接受負責安全人士的監督或指導如何安全地使用本產品和理解所涉及之危險。
30. 本產品僅供家用或在類似環境使用，如：商店內部、辦事處以及其他工作環境的員工廚房區域或類型的環境，切勿於戶外使用。
31. 經常檢查主機、配件、電源線及插頭。如發現有任何損毀或曾經跌落，為免發生危險應立即停止使用，並聯絡信興電器服務中心有限公司進行檢查及維修。
32. 必須使用生產商提供的原裝配件。切勿擅自改裝本產品或使用非生產商提供的零件進行修理，否則可造成危險及維修保養無效。
33. 遵從安全守則及避免釀成意外，如需要維修本產品，請攜同本產品、保修卡(印在包裝盒上，必須剪下保留)、發票或換領收據到信興電器服務中心有限公司，地址印於本說明書的背頁或致電熱線查詢：2406 5666。

2. 清潔及保存注意事項

1. 每次使用後必須將產品徹底清潔，清潔前，必須拔除電源插頭，並待產品完全冷卻。
2. 機身的清潔：可用柔軟的濕布擦拭。若表面污漬太多，可用沾有少量溫和清潔劑的軟布擦拭，然後再以濕布抹淨。
3. 使用後，可用清水或少量中性清潔劑清洗不鏽鋼盒。切勿用汽油、去污粉或粗硬的潔具(如鋼絲刷或百潔布等)清潔本產品。
4. 使用數次後，發熱盤位置或會出現乳白色、啡色或黑色的圓點，這是由於水中含有礦物質。礦物經過加熱轉化成化合物，然後沉澱形成水垢。水的硬度愈高，水垢囤積速度愈快，此乃正常現象。

清除水垢可參考以下方法處理：

- 於注水格內注入清水(切勿超過“最高水位”線位置)；
- 將兩至三片檸檬放入注水格內(或按每升水20克檸檬酸比例加入)；
- 按開關按鈕將水加熱至沸騰，然後關機靜候約20分鐘。將注水格內的水全部倒掉，然後用海綿或軟毛刷擦洗發熱盤位置。完成後，用水沖洗過淨。

注意！ 如發現有檸檬酸味殘留，可再次注水(切勿超過“最高水位”線位置)加熱至沸騰，然後將水倒掉即可。

5. 切勿使用有毒或含腐蝕性的清潔劑進行清潔。
6. 不鏽鋼食物盒邊緣位置較鋒利，清洗或使用時請小心。
7. 待清洗及產品完全冷卻後，可將產品放入紙箱然後儲存在乾爽的環境中。切勿用電源線纏繞在本產品四周或壓住電源線，避免做成電源線損壞。

3. 產品規格

| | | |
|-----------------|--------------------|------------|
| 型號 | RSB-BB212S | RSB-BV212S |
| 顏色 | 湖水藍 | 薰衣草紫 |
| 額定電壓 | 220-240伏特~ 50-60赫茲 | |
| 額定功率 | 270瓦 | |
| 淨重(約) | 1.1公斤 | |
| 產品尺寸(闊 x 深 x 高) | 200 x 130 x 158毫米 | |

4. 產品結構

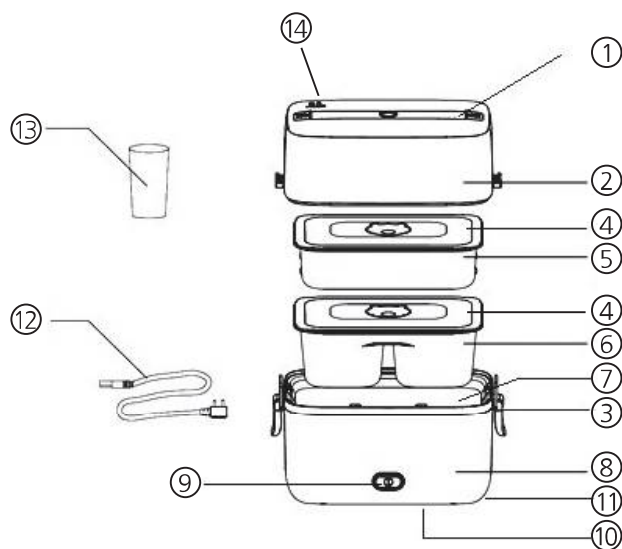

提示：主機(包含開關按鈕及電源接駁位)與電源線屬不可清洗部分。

註：以上圖片僅供參考，尺寸比例或有差異，以實物為準。

4.1 產品部件及配件說明

| 編號 | 部件／配件名稱 | 用途說明 |
|----|---------|--|
| 1 | 頂蓋手帶 | 用於提取產品 |
| 2 | 頂蓋 | 產品上蓋〔運作時，切勿觸摸或靠近此蓋的排氣口〕 |
| 3 | 蓋扣 | 用於鎖定頂蓋及主機 |
| 4 | 容器蓋 | 僅用作保存食物用〔加熱時，切勿使用此蓋〕 |
| 5 | 不鏽鋼單格盒 | 用於蒸飯／翻熱飯菜 |
| 6 | 不鏽鋼雙格盒 | 用於蒸飯／翻熱飯菜 |
| 7 | 注水格 | 注入水的地方(只可注入蒸餾水或清水，切勿使用礦泉水或含鈣化物水) |
| 8 | 主機 | 產品的主要電器部分(內有注水格，切勿注水超過“最高水位”線位置) |
| 9 | 開關按鈕 | 開啟或關閉本產品(開啟時，電源指示燈會亮起) |
| 10 | 通風口 | 位於產品底部。切勿將產品置於地毯、塑膠檯布、紙品或墊子等軟物件上使用，以免堵塞通氣位(如有堵塞，或會造成故障) |
| 11 | 電源接駁位 | 連接電源線 |
| 12 | 電源線 | 連接電源接駁位與電源插座 |
| 13 | 量杯 | 用作量水／量米 |
| 14 | 排氣口 | 排出蒸氣的位置(注意! 蒸煮時切勿將手放近，以免燙傷) |

4.2 建議蒸煮時間

注水量及參考時間表

| 用途 | 組合方式 | 食物分量 | 食物注水量 (毫升) | 注水格水量 (毫升) | 蒸煮時間 (分鐘) |
|------|------|--------|---------------|---------------|--------------|
| 翻熱飯菜 | 單層使用 | 裝滿飯盒 | / | 150 | 15-20 |
| | 雙層使用 | | / | | 20-25 |
| 蒸飯 | 雙層使用 | 1杯米* | 80 | 200 | 30-40 |
| | | 2杯米* | 160 | | |
| | | 1.5杯米* | 120 | | |

* 以附送的量杯為準。

備註： 以上蒸煮時間只供參考，食物可能因為溫度、種類、份量等不同而各有差異，用戶需根據個人經驗及實際情況進行調整。

備註： 不鏽鋼雙格盒只能置於下層使用。

溫馨提示：

- 翻熱飯餸或蒸飯時，必須移除容器蓋。
- 當蒸煮盒正在運作時，請勿觸碰上蓋或接近排氣口，以免燙傷。

5. 使用方法

5.1 蒸煮食物

1. 用量杯於注水格加水至“最高水位”線位置(具體可參照**章節4.2建議蒸煮時間**)，然後將要加熱的飯菜放入不鏽鋼盒內。
2. 放好食物後，先將不鏽鋼雙格盒放入注水格，再將不鏽鋼單格盒放在上方，最後蓋上頂蓋扣好。(如只使用單格盒，仍需先將雙格盒放於注水格內，方能放置單格盒於其上方，然後加熱。)

提示： 放入食物盒前，須先將容器蓋取下。

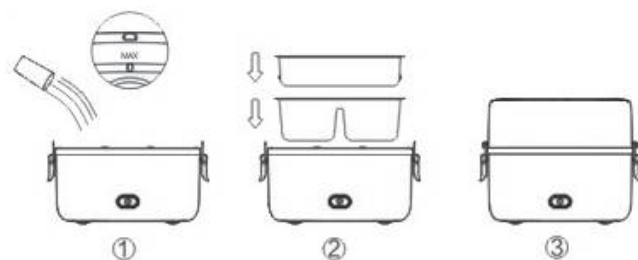

3. 接通電源，按下開關按鈕。當電源指示燈亮起，表示產品已開始運作。



4. 運作完成後，按開關按鈕，電源指示燈熄滅，產品將停止運作。(如烹調時間需延長，須自行按開關按鈕停止運作，重新注水後重啟以延長運作時間。)

備註： 當注水格內水蒸發至較低水位時，保護裝置會啟動並自動斷電，電源指示燈會熄滅，產品將會停止工作。切勿依賴保護裝置關閉本產品。

提示： 當保護裝置啟動後，食物或會出現未充分加熱的情況。

提示： 取出不鏽鋼容器時，須使用隔熱手套，以免燙傷。

5.2 攜帶方式

本產品備有收納式頂蓋手帶，於不使用時可收藏於頂蓋。使用時，於手帶的兩端往內推，扣緊後，即可作提手用，方便攜帶。



提示： 如需打開提手，於加熱完成及產品冷卻後才打開，以免燙傷。

提示： 以提手提起產品前，請先確保蓋扣已扣好，以免打翻食物。

6. 故障排除

如出現以下異常情況或故障，應立即停止使用，並將本產品送往信興電器服務中心有限公司進行檢查及維修。

1. 電源線或電源插頭異常發熱。
2. 稍微屈曲電源線，產品即時出現斷續通電的情況。
3. 產品異常發熱、釋出燒焦味道或冒煙。
4. 當接觸產品的外殼，有感覺到觸電情況。
5. 有部分時間無法自行斷電。
6. 漏水。

7. 特別聲明

1. 本資料上所有內容經過核對，如有任何印刷及內容上的誤解，本公司將保留解釋權。
2. 本產品若有技術改進，會編進新版說明書中，恕不另行通知；產品外觀、顏色如有改動，則以製造商生產資料為準。
3. 如本資料之中英文版本有差異時，應以中文版為準。
4. 使用說明書的電子副本可通過電子郵件發送致客戶。如有需要，可致電信興電工工程有限公司：28612767。

8. 售後服務

1. 由購買收據起之一年保修期內，經信興電器服務中心有限公司之服務人員證實產品故障屬正常使用發生者，本公司將提供免費維修或更換零件服務。經更換之任何損壞／毀零件，將屬本公司所有。保修範圍不包括修理或更換損耗性零件及配件。如使用不當，或作(半)商業用途，或未依照說明書使用，保修服務將無效，本公司將不會承擔任何損壞的維修及賠償。
2. 用戶必須於維修時出示購買／換購及蓋有銷售點／換購中心印章的**產品保修記錄卡(印在包裝盒，必須剪下保留)**，如有任何疑問，請致電信興電器服務中心有限公司熱線查詢：24065666。

Thank you for choosing Rasonic Mini Double-deck Steam Box. Read the operation manual carefully before using and keep the operation manual for your future reference.

Table of Contents

1. Important Safeguards
2. Cleaning and Storage Guideline
3. Product Specifications
4. Product Structure
5. Operation Instruction
6. Trouble Shooting
7. Special Avowal
8. After Sales Services

1. Important Safeguards

Read the operation manual before use, failure or negligence in observing these safety precautions could cause fire, electric shock or personal injuries.

1. Remove and discard all packing materials of the appliance before operation. Clean the stainless steel containers by using sponge moisten with mild detergent.
2. Before connecting to electricity, ensure that the input voltage specified on rating label is consistent with the local voltage and connect the plug to a suitable and grounded socket. Do not use extension cords to avoid overload and risk of fire.
3. The appliance is not intended to be operated by means of an external timer or separated remote control system.
4. Do not cook directly inside the water tank (heating plate).
5. Do not operate the appliance under the following conditions:
 - Uneven or rough surface;
 - Wet or near water area;
 - Next to heat and fire sources (e.g. oven or induction cooker etc);
 - Flammable and poor heat resistant products (e.g. carpet, plastic table cloth, curtains and towel etc);
6. Do not exceed the maximum water indicator “最高水位” to prevent water from spilling out or steam discharging.
7. Do not open the lid during operation, otherwise the boiled water may spill out and cause burns. If necessary, press “On/Off” button to switch off the appliance before open the lid.
8. Always use kitchen utensils with long handles when checking the food inside; To avoid scalding by hot steam, use oven mitts to pick up the food from the appliance.
9. To prevent overheating the appliance, do not cover the appliance or block the steam vent on the lid to avoid lid deformation or discolor.

10. Reserve sufficient space for steam exhausting and radiating during the appliance operating. 10 cm from appliance top and sides is suggested.
11. Make sure the appliance is plugged firmly before use. Otherwise, it may cause cable overheat due to poor contact with electrical source, affect the operation and damage the appliance or cause fire.
12. The appliance equipped with overheat protection function. If continuous operation is needed, shut down for 20 minutes after first trial, wait until the appliance to cool down completely before reusing. Do not rely on overheat protection function to switch off the appliance.
13. The appliance is not equipped with timer. User may adjust water added and cut off the power depending on personal cooking preference. In terms of maximum water level “最高水位”, the entire operation time is around 30 minutes. **Note: Entire heating time may extend after adding water to the water tank.**
14. When pressing the “On/Off” button, do not push it with extra force to avoid damaging the button. After operation, shut down and unplug the appliance to avoid damaging the electronic elements or even causing fire due to long-term connect to the electricity.
15. Avoid using the appliance to cook food which is acidic or alkaline.
16. The appliance may get stained after using periods of time. It is because ingredients (e.g. oil, starch and protein etc.) contain pigment itself. This is a normal phenomenon, causing no damage to human body and usage.
17. Do not switch on the appliance when there is no water inside the water tank. Add water or unplug the power socket immediately when water run out. Be careful when adding water, do not touch the heating plate with bare hands to prevent burns.
18. Never leave the appliance unattended when in use or operate without water in the water tank.

19. After cooking, a lot of vapor and water droplets will remain inside the body and the lid, which is a normal phenomenon. To avoid burns, switch off the appliance and unplug the power, wait for a few minutes before opening the lid to avoid burn by residue heat. Open the lid carefully to avoid condensed water droplets dropping from the lid onto the "On/Off" button or power connector.
20. Great care is necessary in using the appliance, especially near children. Children should be supervised to ensure that they do not play with the appliance. Also, children without adult supervision should not operate, clean and maintain the appliance. Keep them away from the appliance and its power cord.
21. During operation, massive steam will be ejected from the steam vent. Be careful to avoid burns! Do not get your face or hands close to the steam vent during operation or right after use. Avoid using the appliance near the wall or furniture.
22. Do not open the lid, move or shake the appliance during operation, otherwise, massive steam will be released causing burns or danger. Do not touch the product enclosure and heating element when heating or just after use, to avoid burn by hot surface and residual heat.
23. Clean the appliance every time after use, never immerse the appliance, main body, power cord, power plug into water and power connector should not be in touch with water, as it will affect its safety performance and cause electric shock. Make sure the plug is dried before use.
24. Use the power cord with care, do not place heavy objects on the power cord. Never clip, modify, stretch or twist the power cord; when unplugging or inserting the plug, be sure to grasp the power plug itself when plug in or unplug the appliance, and make sure the power cord, the product and the power socket is connected. Otherwise it may cause danger and damage the appliance.
25. Do not operate the appliance when the power cord is tangled, do not hang the power cord over the edge of a table, a counter-top or touch any hot surface, otherwise, it will speed up its deterioration.

26. When not in use or after usage, pull the power plug out of the socket to prevent electric shock due to insulation aging. Do not touch, plug in or remove the plug with wet hands, it can cause electric shock.
27. Always clean the power plug, and ensure the appliance is clean, dust free and oil free to prevent fire.
28. Do not use the appliance outdoor or any purposes other than cooking food. (Misuse can cause potential injury and product damage).
29. The appliance can be used by children aged from 8 years and above and persons with reduced physical, sensory or mental capabilities, or lack of experience and knowledge, if they have been given supervision or instruction concerning use of appliance in a safe way and understand the hazards involved.
30. This appliance is intended to be used in household or similar application such as staff kitchen areas in shops, office and other working environments, by clients in hotels, motels and other residential type environment.
31. Always check the appliances, accessories, power cord and power plug. If the appliance is damaged or dropped, do not use the appliance to prevent danger, and contact Shun Hing Electric Service Center Limited for checking and repairing.
32. Use the parts that are authorized and provided by the manufacturer. Do not use or replace any parts and assembly which is not produced under authorization, otherwise, the warranty becomes invalid.
33. Follow the safety precaution/instruction to prevent accidents from happening, contact Shun Hing Electric Service Center Limited. when repair is needed (address is printed on the back cover of the manual or call 2406 5666 for inquiry), make sure to show warranty card (**printed on the gift box, and must be saved it for future reference**), invoice/redemption voucher during repairing.

2. Cleaning and Storage Guideline

1. Clean the appliance every time after use. Before cleaning, unplug the appliance and wait until the appliance cool down completely.
2. To clean the main body, may use soft wet towel to wipe. If there are too much dirt, you may wipe with mild detergent.
3. After use, clean the stainless steel containers with mild detergent. Never use gasoline, decontamination powder or harsh cleaning tools (e.g. metal brush or scouring pad etc.) for cleaning.
4. Due to the minerals in water, color scale will be found on the heating plate after heating. The harder the water, the quicker the scale will be formed. It is a normal phenomenon.

To remove the water scale, follow the below instructions:

- Fill water into the water tank (do not exceed the maximum water indicator “最高水位”).
- Put 2-3 sliced lemon in the water tank (Or follow the ratio to add 20g citric acid per 1L water).
- Press the “On/Off” button to start until the water boiled. Wait and pour out all water after around 20 minutes. Then clean the heating plate with a sponge or soft brush, and rinse by water in the end.

Notice! To remove the remaining smell of citric acid, boil water (do not exceed the maximum water indicator “最高水位”) again and pour it out afterward.

When the heating plate, main body and the lid is dirt, wipe it with a wet cloth.

5. Do not use toxic and abrasive cleaners for cleaning.
6. Pay attention to the edge of stainless steel containers when cleaning and using.
7. The appliance must be completely cooled and cleaned before storage. Store it in a carton and place it in a dry environment. Never wrap the power cord tightly around the appliance or put any pressure on the power cord to avoid damage.

3. Product Specifications

| | | |
|-------------------------------|---------------------|-----------------|
| Model | RSB-BB212S | RSB-BV212S |
| Color | Luke Blue | Lavender Purple |
| Rated Voltage | 220-240 V~ 50-60 Hz | |
| Rated Power | 270 W | |
| Net Weight (Approx.) | 1.1 kg | |
| Product Dimension (W x D x H) | 200 x 130 x 158 mm | |

4. Product Structure

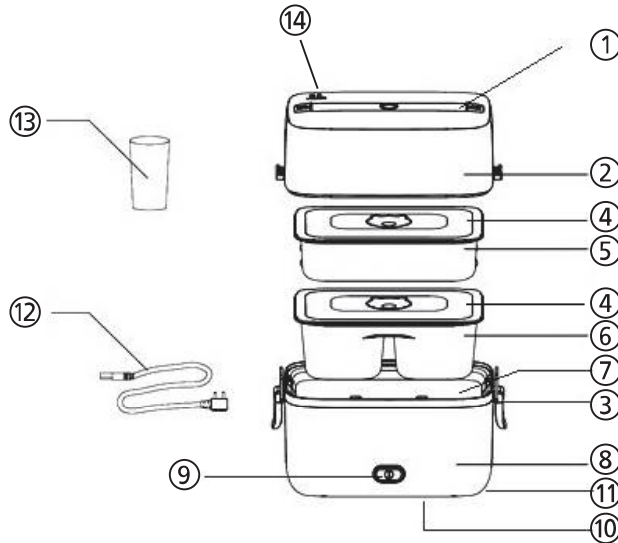

Hints: Main body (including "On/Off" button and power connector) and power cord are non-washable parts/accessories.

Note: The above illustrations are for reference only. Size may differ from real object and subject to the actual appliance.

4.1 Spare Part and Accessories

| Item No. | Name of Parts / Accessories | Description |
|----------|---|--|
| 1 | Handle | Lift up the appliance |
| 2 | Lid | Lid of the appliance (Do not touch or approach the steam vent during operation) |
| 3 | Buckle | Lock the lid and main body |
| 4 | Container cover | Use only for storage (DO NOT use it when cooking/steaming) |
| 5 | Stainless steel container (Single grid) | Use for reheating or steaming food |
| 6 | Stainless steel container (Double grid) | Use for reheating or steaming food |
| 7 | Water tank | The place to add water (Only use distilled water or clean water, do not use mineral water or with calcium substance) |
| 8 | Main body | Core electrical construction of the appliance. It consists of water tank which cannot pour in water exceeding the maximum water indicator "最高水位" |
| 9 | "On/Off" button | To switch "On/Off" the appliance (Power indicator will light on when operating) |
| 10 | Bottom ventilation | Situated at the bottom of the appliance. Do not place the appliance on top of carpet, plastic tablecloth, paper sheet or mat etc. (If the bottom ventilation is clogged, it may cause malfunction) |
| 11 | Power connector | Connect with the power cord |
| 12 | Power cord | Connect with power connector and power socket |
| 13 | Measuring cup | Use for measuring water/ amount of rice |
| 14 | Steam vent | Discharge steam from main body (CAUTION! Do not put your hand nearby to avoid getting scalded) |

4.2 Recommended Cooking Time

Suggested water volume and cooking time

| Purpose | Decks | Food Amount | Add water food (ml) | Add water to water tank (ml) | Steam Time (mins) |
|------------|-------------|-------------|---------------------|------------------------------|-------------------|
| Reheat | Single Deck | Full Box | / | 150 | 15-20 |
| | Double Deck | | / | | 20-25 |
| Steam Rice | Double Deck | 1 cups* | 80 | 200 | 30-40 |
| | | 2 cups* | 160 | | |
| | | 1.5 cups* | 120 | 200 | 30-40 |

* Measure food by given measuring cup.

Note: The cooking time is varied by temperature, types, quantity etc. the above operation time is for reference only, user may adjust the operation time according to the actual cooking condition and experiences.

Note: The double grid stainless steel container must be placed at the bottom when using.

Reminder:

- Before reheating food or steaming, please remove container cover.
- When the appliance is operating, DO NOT touch the lid or steam vent to avoid burn.

5. Operation Instruction

5.1 Steam Food

1. Fill water into the water tank to the maximum water indicator “最高水位” (refer to from **Chapter 4.2 Recommended Cooking Time**). Place the food in the stainless steel container.
2. Once the containers are ready, place the double grid stainless steel container on the water tank first and put the other container on top. Then close the lid and lock up with buckles. (You may use only one of the stainless steel containers according to your needs.)

Reminder: Take off the transparent container cover before steaming.

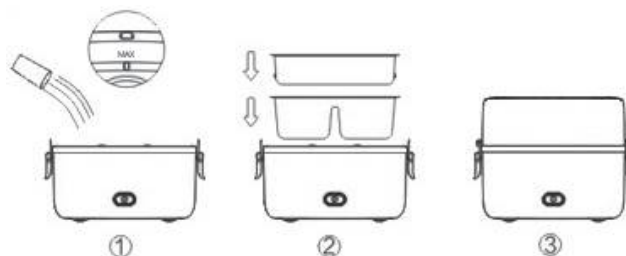

3. Start the operation by pressing the "On/Off" button. When the power indicator is on, the operation starts.



4. When the heating time is reached, press the "On/Off" button again to stop operation, the power indicator light is off. (To extent steaming time, user can turn off the appliance by pressing the "On/Off" button and add water to water tank. Then turn on the appliance again.)

Remark: The operation will be cut when the overheat protection activated due to insufficient water in water tank, the indicator will be turned off. DO NOT rely the overeat protection to switch off the appliance.

Reminder: When the water tank is about to dry up, protection will be activated automatically, food might not be heated as sufficiently.

Reminder: To avoid getting burnt, use insulation gloves while taking out the container.

5.2 Carry the product

While not using the steam box, user can put down the handle. Push both ends to the middle to stand up the handle.



Reminder: After steaming, please wait the appliance cool down and then rise up the handle. Otherwise you may get scald.

Reminder: Before carrying the steam box, please make sure the buckles are well locked, otherwise food or water may run out.

6. Trouble Shooting

If the below conditions occurred, stop using the appliance immediately, and send the appliance to Shun Hing Electric Service Centre Limited to check and repair.

1. If the power cord and power plug is heating abnormally.
2. If the electricity flows discontinuously when the power cord is slightly bended.
3. If the appliance is abnormally hot, emitting burnt smell and smoke.
4. If you get electrically shocked when touch the appliance.
5. If the appliance sometimes couldn't turn off automatically.
6. If there is water leakage.

7. Special Avowal

1. The content in the manual has been checked. Our company reserves the hermeneutic power to any printing errors or misunderstanding on the content.
2. If there are technical improvements on the appliance, the operation manual will be updated in new version without prior notice. The product appearance and specification are subject to the manufacturer information.
3. In case there is any inconsistency or conflict between the English versions and Chinese versions of the terms, the Chinese versions shall prevail.
4. E-copy of user manual can be sent by e-mail on request, please call Shun Hing Electric Works & Engineering Co. Ltd at 2861 2767.

8. After Sales Services

1. For any defect, in the judgement of technician from Shun Hing Electric Service Centre Limited, cause under normal use, our company is responsible for repairing and replacing any parts of the said electrical appliance free of charge within one year guarantee period commencing from the date of purchase. Any defective part which has been replaced shall become our property. Warranty service does not cover the repair or replacement of consumable parts. If appliance is used improperly, for commercial or semi-commercial use, or not following the instructions in the operation manual, the warranty becomes invalid and our company will refuse any liability and repairing cost for the damage caused.
2. User must present the official invoice/redemption voucher and the product warranty card (**Printed on the gift box, and must be saved it for future reference**) with the chop from sales point/redemption center for maintenance. For enquiries, call Shun Hing Electric Service Center Limited hotline at 2406 5666.



SHUN HING GROUP
信興集團
SINCE 1953

 **Rasonic 樂信牌**

信興電工工程有限公司

SHUN HING ELECTRIC WORKS AND ENGINEERING CO., LTD.

辦公室：香港九龍尖沙咀東部麼地道67號半島中心9樓

電話：2861 2767

網址：<http://www.rasonic.com>

圖文傳真：2865 6706

電郵：shew@shunhinggroup.com

Office: 9/F, Peninsula Centre, 67 Mody Road, Tsimshatsui East, Kowloon, Hong Kong

Tel: 2861 2767

Website: <http://www.rasonic.com>

Fax: 2865 6706

E-mail: shew@shunhinggroup.com

保養及維修 Maintenance and Repair Service:

信興電器服務中心有限公司

SHUN HING ELECTRIC SERVICE CENTRE LTD.

香港新界葵涌勝耀街2號信興中心11樓

服務熱線：2406 5666

網址：<http://www.shesc.com/zh>

傳真號碼：2408 0316

11/F, Shun Hing Centre, 2 Shing Yiu Street, Kwai Chung, N.T. HK

Service Hotline: 2406 5666

Website: <http://www.shesc.com/en>

Fax No.: 2408 0316

客戶服務中心：

香港新界葵涌勝耀街2號信興中心1樓

九龍尖沙咀東部麼地道67號半島中心B座9樓

香港天后琉璃街7號柏景中心22樓

澳門慕拉士大馬路193-199號南嶺工業大廈5樓I座

Customer Service Centre

1/F, Shun Hing Centre, 2 Shing Yiu Street, Kwai Chung, N.T.

9/F, Block B, Peninsula Centre, 67 Mody Road, Tsim Sha Tsui East, Kowloon

22/F, Parkview Centre, 7 Lau Li Street, Tin Hau, Hong Kong

Avenida de Venceslau de Morais, No. 193-199, 5 andar - I, Edf. Industrial Nam Leng, Macau

有關最新之香港及澳門客戶服務中心資料，請參閱信興服務中心網址：<http://www.shesc.com/zh>

For the latest information of Hong Kong and Macau service center, please visit <http://www.shesc.com/en>